

Supratec HB2024S Ultra-filtration Membrane Cassette

With Hollow Fiber Membrane - PVDF

Product Data Sheet

Features

The Supratec HB2024S Ultra-filtration Membrane Cassette is a new design of hollow fiber membranes. Supratec Membrane GmbH, located in Simmern/Hunsrück Germany, is the designer and membrane manufacturer of the HB2024S product. Supratec Group has more than 40 years of experience in the field of wastewater treatment, and more than 20 years know-how in the membrane manufacturing. The membrane cassette is assembled in Székesfehérvár, Hungary by Supratec Membrane Kft., or in Shanghai, China by Supratec Membrane Technology Co., Ltd.

This product is made of proprietary polyvinylidene fluoride (PVDF) ultra-filtration membrane with a nominal pore size of 0.03 μm . This high-flux membrane is used for removal of macro-molecules, concentration of organic solutes, microbial and particle removal in water and wastewater treatment. This product is made of strong and durable hollow fibers without any breakage, and is available in different configurations and designs, and may be customized to meet customer requirements.

Features include:

- **Very High Flux**

The HB2024S membrane has exceptionally high sustainable fluxes requiring less square meter than other competitors.

- **Applicable to Wide Range of Feed Water Quality**

The HB2024S cassette is equipped with a very tolerant membrane and a robust product design that allows using HB2024S for a wide range of applications and variable feed water quality.

- **Easy to Clean**

Supratec hollow fiber product is manufactured with proprietary hydrophilic PVDF membranes with anti-fouling characteristics. This membrane is stable, flexible, and easy to clean.

- **Lowest Energy Consumption**

The HB2024S cassette is equipped with proprietary aeration devices providing the lowest and most effective aeration system in the market.

Product Specifications

Model	Supratec HB2024S UF Membrane Cassette
Membrane surface properties	Non-ionic and hydrophilic
Membrane type	Proprietary PVDF
Membrane permeability(Clean water)	>1,500 l/mh/bar
Nominal membrane pore size	0.03 μm

Design Information

Membrane area per module	102.2 m ²
Quantity of module	24 pcs(variable with project demand)
Total Membrane Surface	2,453 m ²
Dimension	1,820*1,745*2,342 mm (L*W*H, net Module)
Back flushable	Yes
Flux rate (MBR application)	10 – 60 l/m ² -h
Flange of air manifold	2 x DN100 PN10
Flange of permeate manifold	1 x DN200 PN10
Supporter	PET
Dry Module Weight	71 kg
Cassette Weight	Around 2,050 kg (dry)/2350kg(wet)

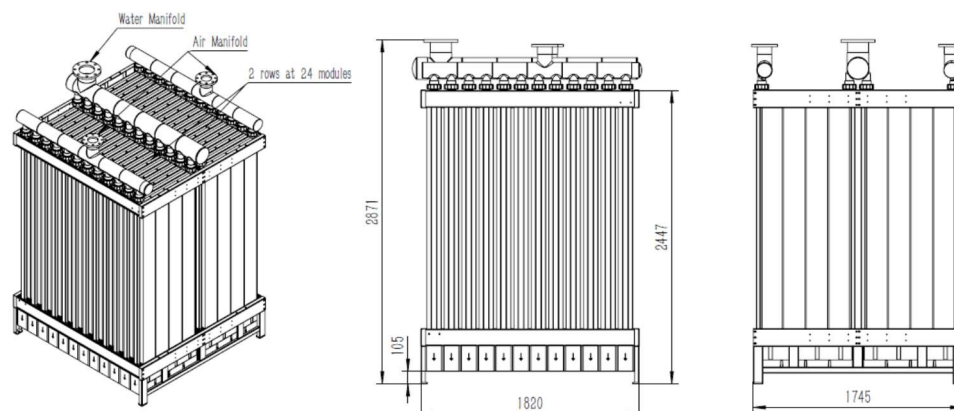
Figure 1 Structure and Dimension of Supratec HB2024S UF Membrane Cassette

Operating Specifications

Maximum operating temperature	40°C (104 °F)
Typical operating pressure (water)	20 – 350 mbar
Cleaning pH Range	2.0 – 11.0
Cleaning period	1 or 2 times/year
Water depth	3.0 – 6.0 meters
Air demand	170 – 340 m ³ /h
Max Chlorine Tolerance	Up to 2,000 ppm as NaOCl
Lifetime Chlorine Tolerance	1,000,000 ppm.hr as NaOCl
Operating Chlorine Tolerance	< 2 ppm

Notes

- Permeate connection diameter here is inner diameter.
- Shipping weight depends on packing material and quantity shipped.
- Module membrane area could be with slight variation but always in application tolerance.
- Product options: Standard is grounding mounted with feet, suspension and lifting is optional.

Storage and Protection

Supratec UF Membrane Cassette should be stored in proper environment. Once the modules come in contact with water or put in use, they should never be stored dry. Typically for long-term shutdown (>7 days), the modules should be cleaned and immersed in proper solution. All cleaning, storage and operational procedures should be based on actual O&M manual provided by Supratec.

Service and Technical Support

Supratec provides a full range of products with different sizes. The design information provided is for the most common products, and Supratec should be consulted for other sizes and requirement if requested. Supratec has an experienced team available to answer questions and provide reasonable technical support.

For more information, please call
Supratec membrane branches:
Germany: +49 6761 967538-10
Hungary: +36 30 4911 474
China: +86 21 31169858
France: +33 172879790
America: +1 4168343099
(HMT Technologies Inc.)

Notice: No freedom from infringement of any patent owned by Supratec Group or an affiliated company is to be inferred. The information and data contained in this document are based on our general experience and are believed to be accurate and reliable. But this information does not imply any warranty or guarantee of performance. Supratec assumes no obligation or liability for the information contained herein. The quality of Supratec products is only guaranteed under our conditions of sale.